



DS DIESSE
FLUID CONTROL

OPERATING INSTRUCTION MANUAL

Magnetic Level gauge

- series DS MG - DS BP
- series DS MG - DS MP
- naval applications (Lloyd's Register approval)



Product origin
Design & Manufacturing
ITALY

Dear Customer,

Thank you for purchasing a DIESE magnetic level gauge.

Our instruments are made with components exclusively of Italian and/or European origin, certified according to international standards.

We recommend a careful reading of this manual before installation or maintenance operations. This will ensure a proper and safety functioning.

At any time and without notice the data can be changed and/or integrated.

For any problems, please contact our technical service at the address below, indicating the following data:

- Magnetic level gauge type
- Code number (punched on the identification plate)
- Date of purchase / installation of the instrument
- Operating conditions (fluid, pressure and temperature)

DIESE S.r.l. Fluid Control
Via dell'Artigianato, 10/12
21040 ORIGGIO (VA) - ITALIA

Tel. +39 02 96731337 Fax: +39 02 96731683
E-mail: info@diessefluidcontrol.com
web: www.diessefluidcontrol.com

DECLARATION OF CONFORMITY to DIRECTIVE 2014/68/CE

The magnetic level gauges described in this IOM have been projected, manufactured and tested in compliance with the applicable requirements of Directive 2014/68/UE (PED – Pressure Equipment Directive).

The company has implemented and maintain a Quality System certified by a Notified Body that satisfy the Directive requirements.

**THESE INSTRUCTIONS SHOULD BE MADE AVAILABLE TO THE OPERATOR IN CHARGE OF THE
INSTALLATION, USE, MAINTENANCE AND REMOVAL.**

FOLLOW THE RECOMMENDATIONS GIVEN IN THIS MANUAL AND OBSERVE THE LOCAL SAFETY REGULATIONS IN FORCE

CONTENT

Point	Magnetic level gauges	Page
	Manufacturer contacts - Declaration of conformity EEC REGULATION 2014/68/UE	2
1	Instrument technical data/Optionals	4
	Operating limits and working conditions	4
	Responsibilities	5
	Regulatory references	5
2	Accessories	5
3	Operating principle	6
4	Preliminary cautions on instrument receipt	6
4.1	Cautions on the storage and handling conditions	7
4.2	Scope of the instrument	7
4.3	Improper use	8
5	Mounting and start up	8
5.1	Caution before installing	8
5.2	Mounting of the instrument	9
6	Dismantling of the instrument	11
7	Maintenance	11
8	Magnetic level gauge for naval applications	14
9	Problem solving	15
10	Disposal	16
11	Technical assistance	16
12	Guarantee	17

1.

Instrument technical data/Optionals

Description:	Magnetic level gauge series DS MG - DS BP and series DS MG - DS MP
Construction material of the main chamber:	Stainless steel AISI 316L
Construction material of the float:	Stainless steel AISI 316L – Titanium grade 2
Connections:	Flanged – Threaded – Weld on
Lower end type:	Flange for inspection and inserting of the float, with drain
Upper end type:	Flat bottom, with vent
Accessories:	<ul style="list-style-type: none">- Shut off cocks, drain and vent<ul style="list-style-type: none">o Cylindrical plug cockso Globe valveso Push button valves- Calibrated scale- Level switch- Level transmitter- Remote control unit- Further particulars on request

Operating limits and working conditions

The type of materials, the limits of use and maximum conditions of use and the permissible fluid (listed in the European Regulation 1272: 2008 - Art. 13 Directive 2014/68 / EU) are assessed in detail and communicated during the order definition.

It is understood that it is the responsibility of the customer to verify the compatibility of the instrument's materials of construction with the fluids used (particularly in the presence of chemicals), as well as the correspondence between data provided to the Manufacturer during design and actual operating conditions.

The Manufacturer will not be responsible for improper use or other applications for which the instrument is designed.

Material type, pressure and temperature limits, serial number are punched on the name plate of the instrument.

Should any questions arise during the installation, please contact the Manufacturer technical service referring to the identification serial number of the instrument.

The magnetic level gauges series DS MG - DS BP and DS MG - DS MP series are classified as pressure equipment (Directive 2014/68/EC Art. 2) and are intended merely to show the level of a fluid in a tank on which they are installed. Therefore they cannot be used for automatic adjustment operations of the level even in the case of any sensor mounted to detect the level.

THEREFORE, THE MAGNETIC LEVEL GAUGES CANNOT BE USED AS SAFETY ACCESSORIES.

The instrument is designed to operate in environments where it is likely the presence of human personnel. Since it is possible the use with temperatures above 60 ° C, it is recommended to carefully consider the need to install any protections to prevent burns due to accidental contact with the instrument (insulation), or to give appropriate notice by danger warning signs.

Limits of responsibility

The manufacturer does not accept responsibility in any case where the above preliminary instructions are not respected and/or the instrument is placed in an operating condition that fails to respect the requirements set forth in this manual.

The installation and use of the magnetic level gauge must guarantee not only its own safety but that of people and buildings; the purchaser/user is therefore responsible for this safety and must proceed as herewith described.

Regulatory references

This manual has been issued in compliance with the applicable requirements of Directive 2014/68/UE (PED – Pressure Equipment Directive) . (Italian Law Decree n. 26 of Febr. 15th)

In addition, the specific reference Standards for the design and construction of the instrument are the following:

- UNI-EN 9606-1 last edition
- UNI-EN ISO 15614-1 last edition
- EN 13445 and related standards
- EN ISO 15609-1 last edition, relative to the qualification of personnel authorized to welding operations as well as to DIN 6700.2
- EU REG n. 1272/2008 last update

2.

ACCESSORIES

SHUT-OFF COCKS, DRAIN AND VENT

It is possible to add shut-off cocks, drain and vent directly to the magnetic level gauge. The connection is made by a special flange; the shut-off valves are used to adjust/stop the flow within the magnetic level gauge chamber (Recommended accessories to facilitate the maintenance operations without having to drain the system).

CALIBRATED SCALE

In stainless steel with millimeter graduation engraved and black coloured.
On request other materials and graduations can be supplied

LEVEL SWITCHES

Such a device is used to monitor particular levels. The binary signal obtained may be transmitted to activate alarms or specific controls. It is placed , depending on the need, by the user to set heights.

Information and recommendations for proper use are available on our web site: www.diessefluidcontrol.com

LEVEL TRANSMITTER

This device is mounted externally to the magnetic level gauge and allows to monitor with both a remote and continuous signal the different levels of the fluid.

The installation and use manual is available on our web site: www.diessefluidcontrol.com

REMOTE CONTROL UNIT

Device equipped with a display that receives the information from the level transmitter.

3

OPERATING PRINCIPLE

The Magnetic level gauge is an integral part of a pressure vessel to which it is connected directly, ensuring, for the principle of communicating vessels, that the level of fluid inside it corresponds exactly to the level of the fluid contained in the tank.

The instrument is composed of a main chamber (a) of non-magnetic material from which depart two connections (b) to the tank (or to any shut-off valves) containing the fluid of which you want to keep the level under control.

A float (c) slides inside the main chamber. It is dimensioned and suitable to the specific weight of the fluid communicated by the Customer; it is equipped with a permanent magnet that is fixed near the floating line on which the magnetic field acts through the red and white rollers (d) freely rotating around their horizontal shaft inside their casing (e).

The change point of the rollers' colour indicates the level reached by the fluid inside the tank. The red rollers area indicates the level of filling of the tank, while the white area the portion of the empty tank.

The instrument can be sectioned (isolated) from the equipment by shut-off cocks (optional but recommended accessory).

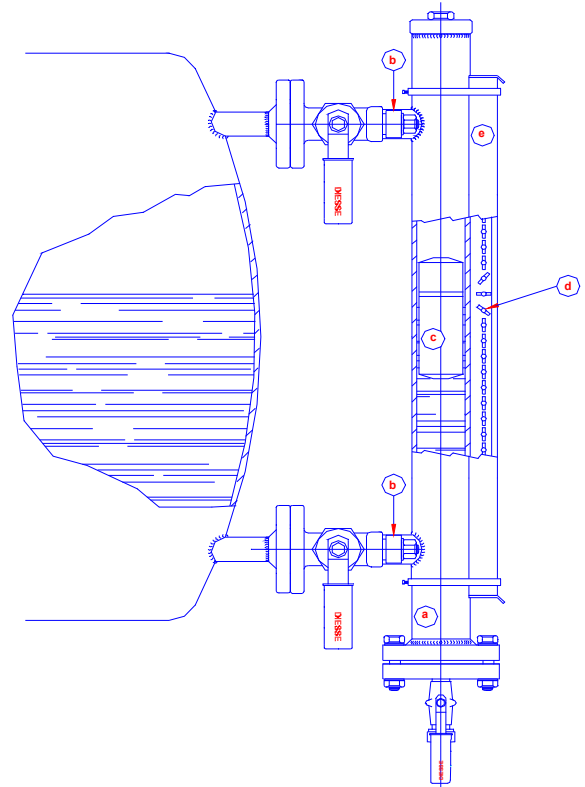

4.

**PRELIMINARY WARNINGS ON INSTRUMENT'S RECEIPT**

On receiving the instrument, before proceeding with installation, make sure:

1. The product has not been damaged during the transport. In this respect we underline that the instrument is manufactured in such a way that a mechanical failure is highly improbable, but its functioning could be compromised in case of accidental falls that could damage the main chamber and the connections to the tank. In case of accidental fall it is strongly recommended to return the instrument to the Manufacturer for the appropriate controls.
2. No components are missing
3. The model and the temperature and pressure rating are as required
4. The material is compatible with both the process fluid and the ambient/atmosphere in which it is to be installed.
5. As regards models supplied with switches and/or transmitters, check that the data reported on the identification plate of the level gauge are compatible with the power supply (detailed instructions/IOM are available on our website www.diessefluidcontrol.com).
6. The instrument, except for particular situation, is shipped completely assembled. Please inform immediately the Manufacturer on any anomaly.

4.1



CAUTIONS ON STORAGE HANDLING CONDITIONS

The instrument must be stored:

- In dry place
- In position such as to avoid any accidental impacts of possible overlaps with other materials
- Away from sources of heat or in places where sudden changes of temperature might occur.
- Away from magnetic or electrostatic fields
- In case of an instruments length > 1,5-2 meter, please provide appropriate supports for the main chamber.

If it becomes necessary to store the product for long periods, it is recommended to closely and regularly monitor packages and materials' conditions.

Handling:

- The handling is only that required to bring the instrument into the installation position.
- During all the possible handling operations both internal and third party transport, great care is recommended to ensure that the instrument does not suffer falls and is packaged in a suitable way to safeguard its integrity.
- During the handling with the instrument in horizontal position, an unintended inclination of the same could cause a fast movement of the float and could compromise the rotation of the rollers. So, before installation, check that all the rollers show the white side; gently lift and inclinate the instrument to enable the float to slide in it. The scrolling of the float to the bottom is not a problem since the instruments is cushioned by springs positioned at its end.

4.2

USE/SCOPE OF THE INSTRUMENT

The instrument is designed for displaying the level in the liquid phase of the fluids inside pressurized tanks and with fluids with the physical/chemical characteristics specified when ordering (specific weight and nature of the fluid, pressure and standard operating temperature and maximum permissible). The pressure and maximum allowable temperatures are indicated on the identification plate on the instrument.

While it is the responsibility of the user to verify that the fluid contained in the tank is compatible with materials used for the construction of the equipment, for any doubt or further explanation please contact the manufacturer.

The magnetic level gauges are utilized to monitor the filling level of the tank and the level of the fluids. They can be installed on containers and tanks that satisfy the technical requirements and are designed to meet the relevant operating parameters. The fluids must be free and low in solids and not be susceptible to gumming, agglomeration or crystallization because the solid particles might magnetize, so creating an agglomeration around the magnet of the float that might cause an incorrect functioning of the instrument.

The magnetic level gauges series DS MG – DS BP and series DS MG and DS MP are pressure instruments and are designed to display the level of a fluid inside the tank on which they are installed.

FOR THIS REASON THE MAGNETIC LEVEL GAUGES CANNOT BE USED AS INSTRUMENTS FOR AUTOMATIC ADJUSTMENT, EVEN IN CASE OF SENSOR FOR LEVEL DETECTION MOUNTED ON THE EQUIPMENT. THEREFORE THE MAGNETIC LEVEL GAUGE CANNOT BE CONSIDERED AS SAFETY ACCESSORIES.

DIESSE assumes no responsibility in the event that the instrument is improperly installed and used as follows:

4.3

IMPROPER USE

Improper use is any use which is different from that expressly intended and in particular the utilization in the following conditions:

- Failure to respect or use contrary to current safety regulations
- Non compliance with the limitations set by the manufacturer as to the type of fluid and the class for which it was designed
- Non compliance of the Manufacturer's limitations with particular regard to the pressure and temperature permissible
- Incorrect mounting and installation of the equipment
- Installation of an instrument damaged by falls or wrong handling
- No installation of appropriate valves to avoid water hammer at equipment start-up.
- No waters purification (such failure could cause the presence of dangerous materials inside the instrument that could affect the proper functioning of the float)
- Incorrect installation after maintenance operations
- Serious deficiencies in the planned maintenance operations
- Modifications or interventions on the instruments which have not been previously discussed with and authorized by the Manufacturer;
- Use of spare parts either not original or of a type not recommended by the Manufacturer
- Use of the equipment by untrained personnel;
- Exceptional events such as earthquakes, floods, willful or accidental blows and other actions that could have caused not immediately perceptible damage to the equipment;
- Maintenance activity with parts under pressure;
- Connection of several magnetic level gauges in greater series than those furnished or designed by the manufacturer.
- Installation without proper insulation and heating of the instrument in environments where temperature could be $< 5^{\circ}\text{C}$;
- Omitted emptying of the instrument during the stops of the equipment especially in environments where the temperature can drop to below 5°C ;
- Non-compliance (total or partial) with the given instructions;
- Use of the instrument at greater value than the limitations permitted and mentioned on the identification plate;
- Use with fluids that are incompatible with the materials used for the construction of the instrument and in any case different from those specified on the order to the manufacturer;
- Instrument exposed to mechanical loads, vibration and shock.

5.

**MOUNTING AND START UP**

5.1

**CAUTIONS/INSTRUCTIONS PRIOR TO INSTALLATION**

For the assembly and disassembly of the equipment, two people with good technical knowledge of maintenance are envisioned. During the activities, operators must wear appropriate individual personal protective means, and all necessary precautions must be taken to avoid accidents.

THE INSTALLATION INCLUDES: THE ASSEMBLING OF THE INSTRUMENT AND ITS PROPER SETTING AND FUNCTION TEST BEFORE THE START-UP

Before installation please assess both the environmental conditions and the system operating conditions.

The limits of use depend both on the execution type and the magnetic level gauge material and are assessed by the parties in the offer and order. The technical data sheets are always provided to the customer and are available on the Manufacturer's website.

Before installation please check both the environmental conditions and the system operating conditions.

The limits of use depend on the execution's type and on the level gauge's material and are assessed by the parties in advance, in the offer/order. The technical specifications of the product/data sheets are always provided to the customer and are still available on the Manufacturer's website.

No particular calibration operations of the instrument are necessary.

IT IS ALSO STRONGLY RECOMMENDED:

- To check that the connections to the tank are perfectly aligned with each other (the connections not perfectly aligned would irreparably damage the gasket seals between the housing and the shut-off valves).
- In case of a level gauge with fixed center to center: please control that on the tank the measure of the center to center distance between the connections is the same mentioned on the instrument identification plate.
- To check the presence of a proper insulation and heating system where environmental conditions could reach temperatures < 5°C. (this option is not in charge of the Manufacturer)

ATTENTION: please utilize only no-magnetic materials

- The personnel in charge of mounting, dismantling and maintenance must have a specialization that allows to understand diagrams, drawings and instructions.
- Unauthorized people cannot access and operate on the systems and devices.
- The magnetic level gauge must not be exposed to mechanical loads, vibrations and shocks .
- The instrument, unless specific exceptions, is shipped fully assembled. Please report to the manufacturer any anomaly found on receipt.
- For instruments with center to center distances exceeding 1.5-2 meters provide appropriate handling and supporting measures after installation.
- It is recommended the installation of valves between the magnetic level gauge and the tank to prevent water hammer during start-up and allow to isolate the instrument in case of need.
- Please note that before using the instrument it must be controlled that the operating conditions of the system comply with what is indicated on the identification plate of the product and the suitable protections against any excess of the maximum permissible limits have been provided.
- The magnetic level gauge is not equipped with a grounding system. The Customer/installer must evaluate the need to extend a grounding system to the equipment on which the instrument is installed.

IN ANY CASE, IN ENVIROMENTS WHERE TEMPERATURE COULD DROP TO BELOW 5°C, AT EVERY EQUIPMENT STOP PLEASE ALWAYS PROCEED TO DRAIN COMPLETELY THE INSTRUMENT.

5.2

MOUNTING OF THE INSTRUMENT

Please proceed in compliance with the below instructions:

- a. Check that the connections to the tank are perfectly aligned with each other and are not damaged
- b. Check that the distance between the connections is the same mentioned on the instrument identification plate
- c. The identification plate is fixed on the lower part of the instrument (unless particular applications). Please check that the operating conditions of the equipment correspond to what reported in the plate
- d. Position the connections in alignment with the tank junctions, making sure to place, between the surfaces, a gasket made of a material suitable for the type of fluid contained in the tank at the maximum operating condition admitted
- e. Put the instrument in vertical position, lift and inclinate it slowly to avoid sudden movement of the float

- f. Place the screws in position for connection, (starting from the upper connection) and tighten them with sufficient torque to ensure a secure connection without damaging the material
- g. BEFORE STARTING THE TANK FILLING, please be sure that the drain and vent plugs, if any, (or valves) are completely closed
- h. Open any (recommended) shut-off cocks DIESSE in a gradual manner in order to avoid excessive stress to the instrument.
- i. The level will begin to rise as soon as the fluid enter into the instrument by moving the float upwards, which, by means of its magnetic system, will cause the rotation of the red rollers.
- j. Once reached the equilibrium point between the tank conditions and the magnetic level gauge, the indication of the level will be stable
- k. Check that during the first hours/day of use no leakages occur. If this is the case, gently tighten the linkage.
- l. If any connection valves are installed and during the first hours of work any leakage is noted, please tighten the stuffing box
- m. If any accessory for the detection and remote transmission is installed (switches and/or level transmitter) make sure the electrical connections are correct and that the command sequences/procedures comply with the instructions of the system designer.
- n. Also verify that the accessories mentioned above are in the correct longitudinal position for the detection of the fluid level.
- o. Make sure that the temperature reached by the switch surface and level transmitter does not exceed the maximum permissible stated by the manufacturer.
- p. In case of any doubt please contact the manufacturer itself or insulate the bodies of the accessories with appropriate thermal insulation, taking care there is no change in the distances between the bodies of the accessories and the magnetic level gauge (contact the Manufacturer for proper information)
- q. If the heating of magnetic level gauge body is foreseen, in the presence of accessories such as switches and level transmitters, please do not use electric heaters, or similar methods, which may affect the electromagnetic characteristics of the accessories themselves and affect the proper functioning of the float.

ATTENTION: Please utilize only no-magnetic materials



WARNING:

If subjected to pressures higher than those for which it is designed, a float might implode or fill with fluid. In this case the float would be blocked inside the main chamber or sunk. In the latter case, the rollers, INCLUDING THE ONES BELOW THE LOWER CONNECTION TO THE TANK, would not rotate and all would show only the white side.



I M P O R T A N T

ALL PRODUCTS ARE CONTROLLED AND SUBJECTED TO HYDROSTATIC TESTS BEFORE SHIPMENT AND THE MANUFACTURER GUARANTEES THEIR INTEGRITY AND CORRECT FUNCTIONING BEFORE RELEASING FOR SHIPMENT.

However, accidental handling, special environmental conditions of transport and storage, strong vibrations or long times between the production and installation, may affect the instrument seal.

A proper tightening is vital to the proper functioning of the instrument.

Therefore, before starting and also after any maintenance operation (especially if the temperatures of use / fluid are very high or very low), it is recommended the control of the tightening values.

6.

DISMANTLING OF THE INSTRUMENT

To section/disassemble the instrument from the tank please take the measures provided by the environmental and safety protection plans (both collective and individual), or follow the recommendations of the operations manager.

In any case please take the appropriate precautions to the type of fluid contained in the tank, waiting, if necessary, that the instrument reaches room temperature, then operate in the following way:

- a. Shut down and empty the installation
- b. Wait until the temperature of the equipment reaches one that will not harm the operators (room temperature)
- c. Then complete the emptying of the gauge
- d. Unscrew the screws and nuts that join the connections to the tank (starting with the lower connections) and remove the gauge, carefully evaluating its weight
- e. Make sure that the equipment restarts only after restoring of the safety operating conditions

Without DIESE shut-off cocks

- f. Empty the tank until a lower level than the bottom connection point
- g. Wait until the complete emptying of the magnetic level gauge
- h. Discharge the residual fluid opening the drain plug or the drain valve if any, adopting the proper cautions to protect the involved personnel and the environment from any possible fluid contamination
- i. Unscrew the screws and the nuts of the connections and remove the instrument from the tank.

With DIESE shut-off cocks

- f. Close the lower shut-off cocks
- g. Open the drain plug or the drain valve, if any, to discharge the residual fluid inside the instrument adopting the proper cautions to protect the involved personnel and the environment from any possible fluid contamination.
- h. Close the upper shut-off cocks
- i. Loosen the nuts that connect the flanges with the DIESE shut-off cocks body and remove the instrument.

NOTE: The sealing gaskets will have to be replaced every time the magnetic level gauge is disassembled. Please contact the manufacturer to get proper spare parts.

7.

**IMPORTANT****MAINTENANCE**

A PERIODIC PREVENTIVE MAINTENANCE, THE CONTROL OF THE TIGHTNESS OR OF ANY TRACES OF LEAKAGE AS WELL AS A REGULAR CLEANING, ARE ESSENTIAL CONDITIONS FOR THE PROPER OPERATION AND THE LIFE INSTRUMENT AND IMMEDIATELY ALLOW TO CORRECT MINOR PROBLEMS THAT, IF NOT TREATED, COULD COMPROMIZE THE MATERIALS AND THE INSTRUMENT'S OPERATION.

DEPENDING UPON THE TYPE AND THE QUALITY OF THE FLUIDS USED AND ALL OPERATING CONDITIONS OF THE SYSTEM, IT IS RECOMMENDED THE SCHEDULING OF REGULAR CONTROLS.

THE USER WILL HAVE TO MONITOR THE CORRECT FUNCTIONING OF THE INSTRUMENT AND PROVIDE THE CLEANING OF THE INTERNAL PARTS TO PREVENT ANY SOLID PARTICLE FROM BLOCKING THE SLIDING OF THE FLOAT OR THE FLUID PASSAGE.

PLEASE PAY PARTICULAR CARE TO THE FLOAT'S SURFACE, PARTICULARLY CLOSE TO THE MAGNET. REMOVE ANY FERROMAGNETIC PARTICLE ATTRACTED BY THE MAGNETIC FIELD TO GRANT THE FUNCTIONING OF THE ROLLERS AND ACCESSORIES.

IF THE FLUID INSIDE THE LEVEL GAUGE IS CLEAN, NO PARTICULAR ACTIONS ARE REQUIRED, IF IT IS DIRTY (GENERATING RESIDUES OR SEDIMENTS) IT IS RECOMMENDED A REGULAR WASHING OF THE CHAMBER.

For any need please contact the Manufacturer Technical Service.



ATTENTION

BEFORE STARTING ANY MAINTENANCE PLEASE BE SURE THAT IN THE OPERATING POINT THERE IS NO PRESSURE AND/OR TEMPERATURE.

NEVER USE SOLVENTS OR OILS TO CLEAN THE SURFACES OF THE INSTRUMENT.

THE PROPER SPARE PARTS ARE DETAILED IN THE CATALOGUE AVAILABLE ON DIESSE WEB SITE. SHOULD NO ORIGINAL SPARE PARTS BE UTILIZED, NO GUARANTEE WILL BE APPLICABLE AND THE MANUFACTURER WILL NOT BE RESPONSIBLE FOR ANY QUALITY OR SAFETY PROBLEM THAT MIGHT ARISE.

The magnetic level gauge is designed so that dismantling is possible solely by means of specific tools in order to avoid any involuntary opening of its parts.

Assuming that:

- It is the responsibility of the user to proceed with maintenance operations and to read carefully the above details on risks; it is advisable to contact the manufacturer for the best way to proceed,
- It is the responsibility of the user to institute appropriate schedules of maintenance, determining the frequency of the same based on his own needs/use of the equipment
- It is the responsibility of the user to evaluate the individual protections means before starting any operation on the system

Here are the maintenance operations recommended:

- **CLEANING OF THE ROLLERS' GLASS CASE TO KEEP A GOOD VISIBILITY OF THE LEVEL**
Warning: before effecting maintenance, wait until the instrument has reached room temperature
Use non-abrasive products and in any case products that are compatible with the glass.
Never use solvents.
- **REGULAR CLEANING/PURIFICATION OF THE EQUIPMENTS**, through verification of the state of the filters so as to avoid foreign bodies which can damage the apparatus.
- **CONTROL OF THE TIGHTNESS** (to guarantee constant tightness): lightly tighten the seal cap and the screws/nuts in several steps
- **INTERNAL CLEANING/WASHING OF THE INSTRUMENT'S CHAMBER AND FLOAT**

ATTENTION:

Before starting the operations please follow the instructions at Point 6 (disassembling of the instrument)

Cleaning operations:

- Do not use solvent or oil
- Use non-abrasive products and in any case verify that they are compatible with the construction materials
- Do not utilize compressed air to dry the instruments; utilize clean dusters

Eventual evidence of internal or external corrosion indicates ambiental conditions adverse to/incompatible with the construction materials of the instrument. It is the responsibility of the user to determine the cause of the problem.

The Manufacturer reserves the right to make changes to these instructions without prior notice and is not responsible for any printing or transcription errors

Extraordinary maintenance:

In some particular cases it might be necessary to replace the float, the rollers' case or the accessories

a. REPLACEMENT OF THE FLOAT

After all evaluations, if the replacement of the float is necessary, proceed as follows:

- contact the manufacturer specifying the reason for the replacement (implosion, drilling, variation in chemical and physical characteristics of the fluid, etc.) and the magnetic level gauge identification data (serial number on the nameplate).
- Insulate the instrument and empty it following the instructions at point 6 (instrument dismantling)
- Ensure that the instrument is completely empty and at room temperature
- By proper tools loosen the bolts/nuts of the lower flange and counterflange, paying attention that none of the components get lost
- Take out the float and replace it with the new one paying attention to insert it in such a way that the magnet is in the upper part (the magnet position can be identified by an engraving on the pipe)
- Ensure that the spring on the drain plug (or on the drain valve) is present and perfectly fixed.
- Reassemble the lower counterflange after replacing the seal with a type suitable to the characteristics of the fluid and the operating conditions. If in doubts please contact the manufacturer
- Follow the instructions relative to the start up as described at point 5 (Installation and start up)

b. REPLACEMENT OF THE ROLLERS CASE

Follow this operational sequence:

- Contact the manufacturer, order the spare parts to be replaced explaining the reason of the replacement and providing the identification data of the instrument (serial number of the nameplate)
- Insulate the instrument and empty it following in detail the instructions mentioned at point 6 (instrument dismantling)
- Ensure that the instrument is completely empty and at room temperature
- Remove any accessory connected to the instrument (i.e. switches, level transmitter, etc.)
- Remove the crimping brackets from the main chamber
- Mount the new rollers' case in compliance with the original position of the manufacturer (the closing cap with the drip ends faced down)
- Reassemble the accessories (if any) paying attention to comply with the original right position (orientation, distance from the main chamber, any repositioning of thermal insulation, connections and sequences of operation)
- Follow the instructions relative to the start up as described at point 5 (Installation and start up)

c. REPLACEMENT AND/OR INSTALLATION OF ACCESSORIES

Follow this procedure:

- Order the accessory (to be replaced or added) to the manufacturer specifying the serial number of the instrument (legible on the nameplate)
- Insulate the instrument and empty it following in detail the instructions mentioned at point 6 (instrument dismantling)
- Ensure that the instrument is completely empty and at room temperature
- Remove the crimping brackets from the main chamber
- Assemble the accessories paying attention to comply with the original right position (orientation, distance from the main chamber, any repositioning of thermal insulation, connections and sequences of operation)
- The instructions/manuals relative to the switches and to the level transmitter are available on our website: www.diessefluidcontrol.com
- Follow the instructions relative to the start up as described at point 5 (Installation and start up)

**MAGNETIC LEVEL GAUGES FOR NAVAL APPLICATION**

The following types can be installed also on ships:

- DS MG - DS BP - SHP
- DS MG - DS MP - SHP
- DS MG - DS BP - NPV - SHP

Product's data / Options: see data sheets available on our website

The above mentioned types can be supplied with **LLOYD'S REGISTER APPROVAL** (General Design Appraisal) – MDAD number TTS/ENG 59225.

In case of use with fuels or flammable fluids, it is recommended to follow the cautions below described:

1. Always check and monitor the good functioning of the magnetic level gauge
2. Provide the appropriate protections that do not allow any triggers of fires (for example by electrical equipment) in the event of loss of fluid or gas.
3. Check that the maximum level of the fluid inside the tank is lower than:
 - the upper connection of the level gauge to the tank for series DS MG – DS BP - SHP and DS MG – DS MP – SHP
 - the vent of the level gauge for series DS MG - DS BP - NPV - SHP
4. Check that the vent pipe is connected to the tank for series DS MG - DS BP - NPV - SHP
5. Provide proper lateral protection of the whole magnetic level gauge (particularly as regards the rollers' case, the switches and the level transmitters and if the instrument is installed in walkway area and/or handling goods area)
6. Check that suitable self-closing shut-off cocks approved for fluid and operating conditions are installed
7. It is recommended to provide a collecting tank under the magnetic level indicator to converge fluids leaks

Limits of use and working conditions: see point 1

Additional limits:

- Flash point of the fluid > 60 ° C
- Installation on passenger ships

Limits of responsibility: see point 1

Accessories: see point 2

Preliminary warnings/recommendations on instrument: see point 4

Warnings/Recommendation on instrument storage: see point 4.1

Use/Scope of the instrument: see point 4.2

Improper use: see point 4.3

Installation and start up: see point 5; 5.1 e 5.2

Dismantling of the level gauge: see point 6

Maintenance: see point 7

9.

PROBLEM SOLVING

PROBLEM	POSSIBLE CAUSE	TENTATIVE SOLUTION
The rollers do not rotate during the filling/emptying of the tank	The specific weight of the fluid is not compatible with the float	Check the specific weight data with the one mentioned on the instrument nameplate and inform the Manufacturer
	The float is damaged or blocked	Check the condition of the float following the instructions at point 7 (Maintenance and extraordinary maintenance – point a)
One or a few rollers do not rotate during the filling/emptying of the tank	There may be particles or dirt inside the rollers' case	Lightly tap the lateral side of the rollers' case, to try to unblock the roller. Do not disassemble in any way the rollers and inform the Manufacturer.
The flags rotation is inverted (i.e. the white colour indicates the presence of fluid in the tank)	No proper reassembling after the maintenance or replacement of the rollers' case.	Unfasten the rollers' case (from the main chamber) and rotate it at 180°, then fix it again. Follow the instructions described at point 7 (Maintenance – operations of extraordinary maintenance - point b)
The rollers show a different height of the actual level of fluid	The specific weight of the fluid is not compatible with the float	Check the data indicated on the nameplate of the instrument and inform the Manufacturer
	Reassembling of the improper float after maintenance or replacement	Check in which direction the float has been inserted in the main chamber following the instructions described at point 7 (Maintenance – operations of extraordinary maintenance – point a)
The colour of the rollers is darkening quickly	The temperature limit is exceeded	Check the data indicated on the nameplate of the instrument and inform the Manufacturer
	The fluid passage and/or the vent are clogged	Check if shut-off cocks are on open position
The speed of rollers rotation is slower than the one of the tank filling	Possible presence of iron particles agglomerate together on the magnet float.	Check the float status following the instructions at point 7 (Maintenance-extraordinary maintenance operations – point a)
The switches are not working		See instructions available on our website: www.diessefluidcontrol.com
The level transmitter does not work		See instructions available on our website: www.diessefluidcontrol.com

10.

**DISPOSAL**

To dispose the component parts of the instruments, please observe the current related and in force laws.

11.

**TECHNICAL ASSISTANCE**

For any need please contact our technical service. To ensure a better service, please indicate the following:

- Type of level gauge
- Serial number
- Date of purchase/of installation of the instrument
- Operating conditions (fluid, pressure and temperature of use)

Our technical department will assess the problem and try to resolve any difficulties where possible. Whenever repairs appear necessary, the manufacturer will agree with the customer the method and time of such repairs. Shipping from customer to the manufacturer is at customer's charge.

For products covered by guarantee

The technical service will effect tests and determine the repairs. Should any responsibility of the manufacturer arise, repairs/replacements will be granted free of charge.

If from analysis of the product it is ascertained that there are no manufacturing defects, and the customer's responsibility for misuse is clear, the manufacturer will charge the customer with all the costs involved.

For products no longer covered by guarantee: the cost of repairs will be debited to the customer based on prior agreement (including the cost of any replacement parts).

12.

GUARANTEE

The guarantee for the level gauge is for 12 months from the date of purchase and can be extended by the manufacturer on the basis of type and characteristics of the product purchased and provided that the customer has complied with storage/handling's recommendations before installation.

It covers eventual manufacturing defects or materials, excluding the parts subject to normal usage such as the gaskets and glasses.

The manufacturer is not responsible for any damage clearly caused by any wrong handling by the forwarder. In case the package is received in damaged conditions it is recommended to accept the material "subject to control/acceptance" so that the conditions of the instrument can be later controlled and, if it's the case, a complaint action can be undertaken towards the courier in charge of transport

The responsibility of the manufacturer is limited to the repair or replacement of the product. The manufacturer is therefore not responsible for eventual damage to other products, structures, personnel directly or indirectly connected to the improper use/installation of the product.

The guarantee is not applicable to disassembled products, repaired or mishandled without the authorisation of the manufacturer. For any problem, therefore, please contact the manufacturer directly in order to evaluate and determine any eventual production defect.

In particular, the guarantee is not valid in the following cases:

- Omitted controls by the user prior to installation, in detail:
 - a) *Verification that the data shown on the product label correspond to the requested product*
 - b) *Verification that the material is both compatible with the fluid of the process and with the ambient/atmosphere in which it is installed*
 - c) *Careful verification that during the transport the product has not been damaged*
- Repairs by personnel not authorised by the manufacturer
- Damages caused by fire, short circuits and natural disasters
- Inappropriate handling/installation executed differently from what indicated in the manual of installation-use- maintenance available on company website at the address www.diessefluidcontrol.com
- Fluid non-compatible with the materials used in the construction of the product
- Operating temperature and pressure different from those indicated on the offer /order
- Use of non-original spare parts
- Accidental shocks
- Cleaning of the installation either not effected or not effected correctly (presence of foreign bodies/scales on the installation)
- Water equipment purification not effected (with the consequence of glass erosion)
- Non-suitable package in case of shipment from the Customer to the final User or in case of return from the Customer to the Manufacturer due to a complaint
- Destination different than the one for which have been designed, particularly the instruments subjected with Regulation 2014/68/EU