



DS DIESSE
FLUID CONTROL

OPERATING INSTRUCTION MANUAL

Glass level gauges

- reflex level gauge
- transparent level gauge
- for classified areas (ATEX)
- for naval applications (Lloyd's Register Approval)
- weld-on level gauge
- glass tube level gauge



Product origin
Design & Manufacturing
ITALY

Dear Customer,

Thank you for purchasing a DIESE glass level gauge.

Our instruments are made with components exclusively of Italian and/or European origin, certified according to international standards.

We recommend a careful reading of this manual before installation or maintenance operations. This will ensure a proper and safety functioning.

At any time and without notice the data can be changed and/or integrated.

For any problems, please contact our technical service at the address below, indicating the following data:

- Level gauge type
- Date of purchase / installation of the instrument
- Operating conditions (fluid, pressure and temperature)

DIESE S.r.l. Fluid Control
Via dell'Artigianato, 10/12
21040 ORIGGIO (VA) - ITALIA

Tel. +39 02 96731337 Fax: +39 02 96731683
E-mail: info@diessefluidcontrol.com
web: www.diessefluidcontrol.com

DECLARATION OF CONFORMITY to DIRECTIVE 2014/68/CE

According to the definition of Article 2 Paragraph 1, DIESE glass level gauges are pressure accessories. On the basis of their small internal volume V (<1L) and small nominal size DN, all our glass level gauges (Reflex and Transparent) fall under the requirements of Art. 4 Paragraph 3, referred to as Sound Engineering Practice (SEP).

Therefore, and in the context of PED, the CE marking is not necessary.

**THESE INSTRUCTIONS SHOULD BE MADE AVAILABLE TO THE OPERATOR IN CHARGE OF THE
INSTALLATION, USE, MAINTENANCE AND REMOVAL.**

FOLLOW THE RECOMMENDATIONS GIVEN IN THIS MANUAL AND OBSERVE THE LOCAL SAFETY REGULATIONS IN FORCE

INDEX

Point	Reflex And Transparent Level Gauges	Page
	Manufacturer contacts - Declaration of conformity EEC REGULATION 2014/68/UE	2
1	Instrument technical data/Options	4
	Operating limits and working conditions	4
	Responsibilities	4
2	Accessories	5
3	Preliminary cautions on instrument receipt	6
	Instruments storage: warnings	6
3.1	Scope of the instrument	6
3.2	Improper use	6
4	Mounting/installation and start up	7
4.1	Cautions before installing	7
4.2	Mounting of the instrument with grinded pipes	8
4.3	Mounting of the instrument at fixed distance between centers	8
4.4	Mounting of instruments equipped with illuminator - CAUTIONS	9
4.5	Instruments equipped with safety balls - CAUTIONS	9
4.6	Instruments equipped with pusher and safety ball - CAUTIONS	10
4.7	Instruments equipped with weight closing for handles or push button valve – CAUTIONS	10
5	Tightening control procedure	10
6	Sealing test procedure	11
7	Dismantling of the instrument	11
8	Maintenance	12
8.1	Instructions for a correct replacement of glasses and gaskets	13
8.2	General cautions on the use/replacement of glasses	14
8.3	Characteristics and limits of the glasses use (reflex and transparent)	15
9	Glass level gauges for classified areas (Atex)	16
10	Glass level gauges for naval applications (Lloyd's Register approval)	17
11	Weld-on level gauges	18
12	Glass tube level gauges	20
13	Disposal of glass level gauges	21
14	Technical assistance	21
15	Guarantee	22

1.

Instrument technical data / Options

Description:	Single/multiple glass level gauge with reflex glasses Single/multiple glass level gauge with transparent glasses
Centre to centre distance:	Variable - Fixed
Materials:	Carbon steel - Stainless steel - Special on request/tailor made
Glass type:	Borosilicate DIN 7081 (reflex - transparent)
Connections:	Flanged - threaded - Weld on
Shut-off valves:	Shut-off cocks, Monolithic shut-off cocks, Globe valves
Accessories:	<ul style="list-style-type: none">• Safety ball• Pusher• Cocks Handle lock• Illuminator• Calibrated scale• Minimum level arrow• Non frosting extension• Continuous reading• Remote control• Weight closing for handles• Mica or PCTFE protection• Further particulars on request

Operating limits and working conditions

Compatibility with the fluid, maximum pressure and maximum temperature permitted must be evaluated/discussed with the Manufacturer in advance.

Operating limits and maximum conditions are detailed on each product's data sheet which can be viewed and downloaded from DIESSE website. In case of doubts, please call our technical service.

RECOMMENDATIONS for instruments equipped with reflex glasses:

The choice of this type is not recommended in case of:

- Fluids with a corrosive power against glasses (example: caustic, fluoridic acid, citric acid...)
- Steam at high pressures
- Instrument subject to frequent thermal shock

In the above mentioned cases the glass must be protected with special shields in MICA or PCTFE and therefore it is necessary to provide a level indicator with transparent glasses

Limits of responsibility

The manufacturer does not accept responsibility in any case where the above preliminary instructions are not respected and/or the equipment is placed in an operating condition that fails to respect the requirements set forth in this manual.

The installation and use of the gauge must guarantee not only its own safety but that of people and buildings; the purchaser/user is responsible for this safety and must proceed as herewith described.

2.

ACCESSORIES:

SAFETY BALL

It's in stainless steel AISI 316, and it is placed in a special seat inside the DS GR18 valves (upper and / or lower), to block the fluid outlet in the event of breakage of the glass (breakage however unlikely if user performs proper maintenance).

The valves type DS SHV globe are always equipped with safety balls (upper and lower).

The ball/s therefore avoids, in case of breakage of the crystal, the sudden emptying of the tank.

Caution:

- Foreign bodies generated during system use may compromise the working operation.
- Sudden pressure fluctuations may cause the coming into operation of safety balls when not necessary, restricting the normal flow inside the instrument (see section 4.5).

PUSHER

Device applied to the shut-off valves fitted with safety balls: it allows you to reposition, once it comes into operation, the safety ball in its housing by restoring the proper functioning of the level gauge.

It is in stainless steel AISI 316 and only for shut-off valves type DS GR18.

COCKS HANDLE LOCK

To be mounted on the shut-off cocks to limit the handling

CALIBRATED SCALE

In stainless steel with millimeter graduation engraved and black coloured.

On request other materials and graduations can be supplied

MINIMUM LEVEL ARROW

Stainless steel arrow to indicate the minimum level of the fluid that must be maintained inside the tank

NON FROSTING EXTENSION

Acrylic transparent resin slab positioned on the glass of the level gauge (both reflex and transparent glass) that avoid the frost formation on the external surface of the glass to enable the level reading.

This accessory is recommended in case of fluid temperature < 0°C.

CONTINUOUS READING

Particular execution of a multiple level to avoid the blind areas between the elements of the instrument and enable a total reading

REMOTE CONTROL

Recommended in case of installation of a level gauge in such position that an easy opening/closure is not possible. Cable or chains are not supplied by the Manufacturer.

WEIGHT CLOSING FOR HANDLES

It's a device that ensure the shut-off cocks closure even in case of the operator absence. To view the level is therefore required a manual operation (see point 4.7).

ILLUMINATOR

It's a lamp positioned on the back side of transparent level gauges installed in particular conditions to improve visibility.

3.



PRELIMINARY WARNINGS ON INSTRUMENT'S RECEIPT

On receiving the instrument, before proceeding with installation, make sure:

1. The product has not been damaged during the transport
2. The model and the temperature and pressure ratings are as required
3. The material is compatible with both the process fluid as well as with the ambient/atmosphere in which it is to be installed
4. As regards model equipped with illuminator lamp, all data reported on the identification plate of the level gauges are compatible with the power supply
5. In case of installation in a classified area, the instrument has the proper plate with the symbol



WARNINGS ON STORAGE CONDITIONS

The instrument must be stored:

- In dry place
- In position such as to avoid any accidental impacts or possible overlaps with other materials
- Away from sources of heat or in places where sudden changes of temperature might occur

If it becomes necessary to store the product for long periods, it is recommended to closely and regularly monitor packages and materials' conditions.

3.1

USE / SCOPE OF THE INSTRUMENT

While it is the responsibility of the user to verify that the fluid contained in the tank is compatible with materials used for the construction of the equipment, for any doubt or further explanation please contact the manufacturer.

The equipment must be used exclusively for displaying the level reached by fluid in a in which the pressure and temperature do not exceed the limits set by the manufacturer.

The level reached by the fluid inside a tank, either open-air or closed and in which the pressure above the fluid surface is equal to or greater than atmospheric pressure, is indicated by the height level of the fluid in the gauge.

The user can request that the Manufacturer add a visual indicator (for example calibrated scale) in order to improve the interpretation of the indications of the level gauge.

3.2

IMPROPER USE

Improper use is any use which is different from that expressly intended and in particular the utilization in the following conditions:

- Failure to respect or use contrary to current safety regulations

- Failure to respect the limitations set by the manufacturer, particularly with regard to the maximum temperatures and pressures permissible
- Incorrect mounting and installation of the equipment
- Failure to waters purification (such failure could cause the erosion of glasses see points 8.2 and 8.3)
- Incorrect installation after maintenance operations
- Total or partial non-observance of the prescribed maintenance operations
- Modifications or interventions on the instruments which have not been previously discussed with and authorized by the Manufacturer;
- Use of spare parts either not original or of a type not recommended by the Manufacturer
- Use of the equipment by untrained personnel;
- Exceptional events such as earthquakes, floods, willful or accidental blows and other actions that could have caused not immediately perceptible damage to the equipment;
- Maintenance activity with parts under pressure;
- Connection of a number of elements beyond those furnished by the manufacturer.
- Installation without proper insulation and heating of the instrument in environments where temperature could be $< 5^{\circ}\text{C}$
- Omitted emptying of the instrument during the stops of the equipment especially in environments where the temperature can drop to below 5°C .
- Non-compliance (total or partial) with the given instructions

4.



INSTALLATION AND START UP

4.1



INSTRUCTIONS PRIOR TO INSTALLATION

For the assembly and disassembly of the equipment, two people with good technical knowledge of maintenance are envisioned. During the activities, operators must wear appropriate individual personal protective means, and all necessary precautions must be taken to avoid accidents.

THE INSTALLATION INCLUDES: THE ASSEMBLING OF THE INSTRUMENT AND ITS PROPER SETTING AND FUNCTION TEST BEFORE THE START-UP

Before installation please evaluate both the environmental conditions and the system operating conditions.

The limits of use depend both on the execution type and the level gauge material and are evaluated and assessed by the parties in the offer and order. The technical data sheets are always provided to the customer and are available on the Manufacturer's website.

Before installation please check both the environmental conditions and the system operating conditions.

The limits of use depend on the execution's type and on the level gauge's material and are assessed by the parties in advance, in the offer/order. The technical specifications of the product/data sheets are always provided to the customer and are still available on the Manufacturer's website.

It is also strongly recommended:

- To check that the connections to the tank are perfectly aligned with each other (the connections not perfectly aligned would irreparably damage the gasket seals between the housing and the shut-off valves).
- In case of a level gauge with fixed center to center: please control that on the tank the measure of the center to center distance between the connections is the same mentioned on the instrument identification plate.
- To check the presence of a proper insulation and heating system where environmental conditions could reach temperatures $< 5^{\circ}\text{C}$. (this option is not in charge of the Manufacturer)

IN ANY CASE, IN ENVIROMENTS WHERE TEMPERATURE COULD DROP TO BELOW 5°C, AT EVERY EQUIPMENT STOP PLEASE ALWAYS PROCEED TO DRAIN COMPLETELY THE INSTRUMENT.

4.2

MOUNTING of the instruments with grinded pipes

Proceed as follows:

- Insert the grinded pipes in the support of the upper and lower taps and lightly tighten the sealing caps
- Verify that the connections to the process are perfectly in line with each other and not damaged
- Position the connections in alignment with the tank junctions, making sure to place, between the surfaces, a gasket of material suitable for the type of fluid contained in the tank
- Place the screws in position for connection, making sure to start with mounting those farther down, and tighten with sufficient torque to ensure a secure connection without damaging the material
- Place the level housing, rotating it on its vertical axis, in the angular position best adapted for visual requirements
- Tighten the sealing caps
- Verify that the tightening values of bolts and nuts correspond to the value indicated on the data sheets provided with the product and available on Manufacturer's website
- Verify the need to leave the shut-off valves closed during the first stages of start-up, in order to avoid dangerous "head butts" to the glasses and compromise their sealing or the instrument features
- Check that during the first hours of use no leakages occur. If this is the case, gently tighten the sealing cap, screws and holding nuts in compliance with the procedure described at point 5 of this IOM.

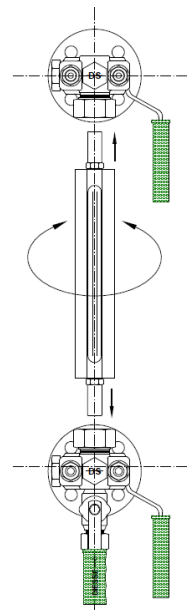

4.3

MOUNTING of the instrument with fixed centre to centre distance

Proceed as follows:

- Verify that the connections to the process are perfectly in line with each other and not damaged
- Position the connections in alignment with the tank junctions making sure to place a gasket, between the surfaces, of material suitable for the type of fluid contained in the tank
- Place the screws in position for connection, making sure to start with mounting those farther down, and tighten with sufficient torque to ensure a secure connection without damaging the material
- Verify that the tightening values of bolts and nuts correspond to the value indicated on the data sheets provided with the product and available on Manufacturer's website
- Verify the need to leave the shut-off valves closed during the first stages of start-up, in order to avoid dangerous "head butts" to the glasses and to compromise their sealing or the instrument integrity
- Check that during the first hours of use no leakages occur. If this is the case, gently tighten the sealing cap, screws and holding nuts in compliance with the procedure described at point 5 of this IOM.

4.4

MOUNTING of the instrument equipped with illuminator lamp - WARNING

Particular attention must be paid during the installation of the illuminator lamp (if provided)



THE DIFFUSER, ESPECIALLY IF IN BOROSILICATE GLASS IS VERY FRAGILE. REMOVE FROM THE PACKAGE AND POSITION IT ON A PLAN



BEFORE INSTALLING MAKE SURE THAT THE DATA ON THE PLATE ARE COMPATIBLE WITH THE EQUIPMENT. SEE PROPER INSTRUCTIONS AND CERTIFICATION PROVIDED

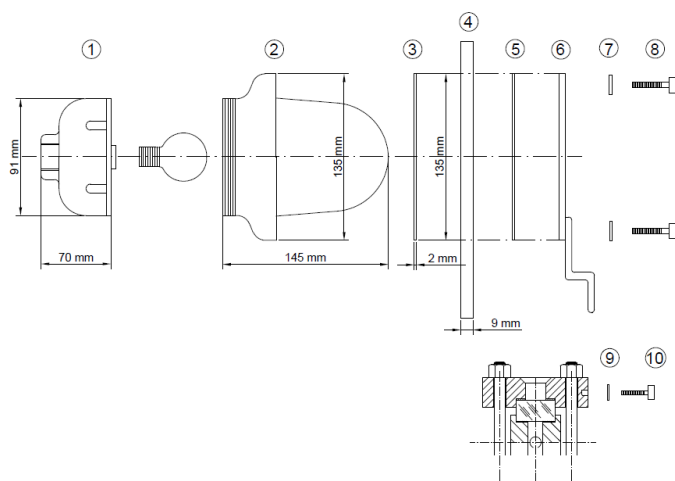

Components:

1. Illuminator body
2. Cover
3. Cushion gasket
4. Diffuser
5. Cushion gasket
6. Support
7. Washer
8. Nut
9. Washer
10. Nut

Mounting instructions as follows:



OPERATIONS TO BE CARRIED OUT WITH EXTREME CAUTION, ESPECIALLY IF THE DIFFUSER IS IN BOROSILICATE GLASS.

- a. Insert the bulb in the illuminator (1)
- b. Screw the cover (2) to the end
- c. Place the cushion gasket (3) in contact with the illuminator on the proper plan
- d. Gently position the diffuser (4) on the illuminator
- e. Place the cushion gasket (5) in contact with the diffuser
- f. Insert the media (6) matching the holes with screws (8)
- g. Gently tighten the three screws gradually and (8) interposing the washers (7)
- h. Rest the support (6) on the cover livelletta matching the holes for the screws
- i. Tighten the two screws (10) interposing the washers (9)

4.5

MOUNTING of the instrument equipped with safety balls - WARNING

The safety balls function in case of glass breakage to protect the equipment preventing the tank from emptying.

WARNING: SUDDEN PRESSURE FLUCTUATIONS MAY CAUSE THE COMING INTO OPERATION OF SAFETY BALLS WHEN NOT NECESSARY, RESTRICTING THE NORMAL FLOW INSIDE THE INSTRUMENT. SO IT IS RECOMMENDED:

The Manufacturer reserves the right to make changes to these instructions without prior notice and is not responsible for any printing or transcription errors

- **AT START UP:** MAINTAIN A CONSTANT PRESSURE VALUE by opening slowly the shut-off cocks to avoid sudden pressure fluctuations
- **AFTER INSTALLATION:** IF ANY SUDDEN FLUCTUATION OF PRESSURE OCCUR, IMMEDIATELY CHECK IF THE LEVEL IS CORRECTLY VISUALIZED

4.6

USE OF THE INSTRUMENT EQUIPPED WITH PUSHER FOR SAFETY BALL - WARNING

- The pusher is provided to enable the return of the safety ball in its original position when its action is completed.
- Wear suitable gloves in case of any contact with the pusher to prevent any problem due to high temperatures.

4.7

USE OF THE INSTRUMENT EQUIPPED WITH WEIGHT CLOSING FOR HANDLES OR PUSH BUTTON

This accessory involve a manual action to visualize the level



IMPORTANT

All products are controlled and subjected to hydrostatic tests before shipment and the manufacturer guarantees their integrity and correct functioning before releasing for shipment.

However, accidental handling, special environmental conditions of transport and storage, strong vibrations or long times between the production and installation, may affect the instrument seal.

A proper tightening is vital to the proper functioning of the instrument.

Therefore, before starting and also after any maintenance operation (especially if the temperatures of use / fluid are very high or very low), it is recommended the control of the tightening values.

5.

TIGHTENING CONTROL PROCEDURE

When completed installation, please isolate the gauge by closing the upper and lower shut-off valves and drain and make sure that the level gauge is not under pressure and there is fluid in it.

- Check the torque value, which must respect the values indicated by the manufacturer in technical data sheet available on DIESSE web site.
- In the event of abnormal values, immediately adjust the tightening (in the manner described below).
- Once operation is completed reopen the valves and re-start the level indicator.
- The control of the torque value/tightening should be carried out periodically to prevent sealing problems or losses especially in the presence of dangerous fluids and in the case of occasional use of the level gauge or changes in the operating conditions.

Tightening instructions to ensure a constant seal:

- **Tighten the screws and nuts** according to the sequence shown on the right.
- **Always start from the center and alternate between the two sides**, (as showed in the picture) then tighten screws and nuts until you reach the exact tightening torque specified by the manufacturer and reported in the technical data sheet available on our web site.

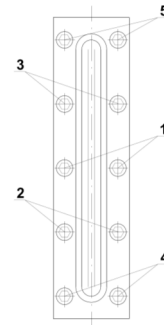
**IMPORTANT**

Should any anomalous result arise during the control, it is recommended to repeat a SEALING TEST as described at point 6.

6.**SEALING TEST PROCEDURE**

1. After the proper installation of the level gauge and the control of the torque values, before proceeding with the sealing test please be sure that all the shut-off cocks are closed and the level gauge is empty
2. Allow to slowly fill the indicator with the process fluid (by opening the upper and lower cocks slowly and leaving closed the drain valve)
3. Now the level gauge should be in pressure. Check that no leakages are occurring
4. If the test is passed, it's allowed to start the operations

7.**DISMANTLING**

- a. Shut down and empty the installation
- b. Wait until the temperature of the equipment reaches one that will not harm the operators (room temperature)
- c. Then complete the emptying of the gauge
- d. Unscrew the screws and nuts that join the connections to the tank (starting with the lower connections) and remove the gauge, carefully evaluating its weight
- e. Make sure that the equipment is restarted only after the safety operating conditions have been reinstated

8.

**I M P O R T A N T****M A I N T E N A N C E**

A PERIODIC PREVENTIVE MAINTENANCE, THE CONTROL OF THE TIGHTNESS OR OF ANY TRACES OF LEAKAGE AS WELL AS A REGULAR CLEANING, ARE ESSENTIAL CONDITIONS FOR THE PROPER OPERATION AND THE LIFE INSTRUMENT AND IMMEDIATELY ALLOW TO CORRECT MINOR PROBLEMS THAT, IF NOT TREATED, COULD COMPROMIZE THE MATERIALS AND THE INSTRUMENT'S OPERATION.

DEPENDING UPON THE TYPE AND THE QUALITY OF THE FLUIDS USED (pH in case of water) AND ALL OPERATING CONDITIONS OF THE SYSTEM, IT IS RECOMMENDED THE SCHEDULING OF REGULAR CONTROLS.

CAUTION: ANY SIGN OF CORROSION INSIDE OR OUTSIDE THE INSTRUMENT SHOULD BE CAREFULLY EVALUATED BY THE USER IN ORDER TO UNDERSTAND THE CAUSE AS SOON AS POSSIBLE.

If necessary, contact the Manufacturer's Technical Service.

**A T T E N T I O N**

BEFORE ANY MAINTENANCE OPERATION PLEASE ENSURE THAT ON THE SYSTEM THERE IS NO PRESSURE AND/OR TEMPERATURE.

DO NOT USE ANY SOLVENT OR OIL TO CLEAN THE INSTRUMENT.

THE PROPER SPARE PARTS ARE DETAILED IN THE CATALOGUE AVAILABLE ON DIESSE WEB SITE. SHOULD NO ORIGINAL SPARE PARTS BE UTILIZED, NO GUARANTEE WILL BE APPLICABLE AND THE MANUFACTURER WILL NOT BE RESPONSIBLE FOR ANY QUALITY OR SAFETY PROBLEM THAT MIGHT ARISE.

The gauge is designed so that dismantling is possible solely by means of specific tools in order to avoid any involuntary opening of its parts.

Assuming that:

- It is the responsibility of the user to proceed with maintenance operations and to read carefully the above details on risks; it is advisable to contact the manufacturer for the best way to proceed,
- It is the responsibility of the user to institute appropriate schedules of maintenance, determining the frequency of the same based on his own needs/use of the equipment
- It is the responsibility of the user to evaluate the individual protections means before starting any operation on the system

here are the maintenance operations recommended:

a. CLEANING THE GLASS TO KEEP A GOOD VISIBILITY OF THE LEVEL

Warning: before effecting maintenance, wait until the instrument has reached room temperature

Use non-abrasive products and in any case products that are compatible with the material of the glasses (borosilicate)

Never use solvents.

- b. REGULAR CLEANING/PURIFICATION OF THE EQUIPMENTS**, through verification of the state of the filters so as to avoid foreign bodies which can damage the apparatus. Should the instrument be installed on a steam boiler, it will be necessary to control the water pH regularly. High pH values cause a faster glass erosion with consequent leakages (see point 8.2)

- c. **CONTROL OF THE TIGHTNESS OF THREADED PARTS** (to guarantee constant tightness): lightly tighten the seal cap and the screws/nuts in several stages (for the level: commence with the centre and alternate on the two sides - see point 5). As regards the tightening torque values of housing screws, please refer to the data sheet of each product available on company website at the address www.diessefluidcontrol.com

Eventual evidence of internal or external corrosion indicates ambient conditions adverse to/incompatible with the construction material of the instrument. It is the responsibility of the user to determine the cause of the problem.

8.1

INSTRUCTIONS FOR THE REMOVAL AND REPLACEMENT OF GLASSES AND GASKETS

Assumptions:

- The glass and gaskets replacement requires such specific devices and tools that the operation by personnel not specifically trained to do so is not advised
- The level gauge is designed so that dismantling is possible solely by means of specific tools in order to avoid any involuntary opening of its parts
- The glass must be handled with caution avoiding the contact of their surface with any object that potentially could damage it. In case of presence of a Mica shield protection do not touch its surface.
- The supplied glasses are borosilicate toughened to increase strength, but the usage limits set by the manufacturer and previously described in the warnings in section 8.2 must be always checked.

Should the customer decide to proceed with its own personnel and tools for maintenance operations, such as the replacement of the glass and/or the gaskets, it is **IMPORTANT**:

- That two people with good technical knowledge of maintenance are envisioned
- The customer contact the manufacturer to decide the proper parts and get instructions
- To carefully read the instructions reported in the use and maintenance manual. Updated release is always available on the manufacturer website www.diessefluidcontrol.com
- The operators wear appropriate individual personal protective means and all necessary precautions must be taken to avoid accidents

Before starting any maintenance operation, it is important to wait until the temperature of the equipment reaches the room temperature

Before dismantling the glass be sure that the instrument is not under pressure, the temperature is the ambient temperature, the shut-off cocks are closed and no fluid is inside the instrument

1. Unscrew the tightening bolts and nuts and be sure that when it is opened no parts fall
2. Remove all gaskets residues from the housing. Use non-abrasive products and in any case products that could incise the glass housing (any incision will affect the glass sealing)
3. Carefully clean all components by non-abrasive products

Mounting:

- 1) Insert the sealing gasket in the housing, put the glass over (if it's a reflex type the prismatic surface must be in contact with the fluid) and then the cushion gasket; in case of a transparent type, if foreseen, insert the mica shields (or the one in PCTFE) between the sealing gaskets and the glass (it must perfectly adhere to the glass surface in contact with the fluid)
- 2) Position the cover avoiding any movement of glass and gasket, even slightly
- 3) Proceed by tightening the fitting screws in the cross sequence. The tightening torque is mentioned on the product data sheet.

Before restarting the equipment: Leave the shut-off valves closed in order to avoid dangerous "head butts" to the glasses and their seal. Restart as showed at point 4.

During first steps of start-up:

If small leakage of fluid are noted, gently tighten the stuffing box, the screws and sealing nuts (see point 5.)

The Manufacturer reserves the right to make changes to these instructions without prior notice and is not responsible for any printing or transcription errors

Reflex housing

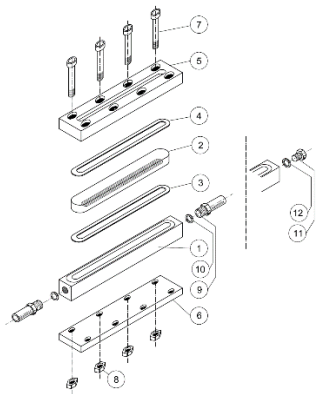

1. Level gauge body
2. Reflex glass
3. Sealing gasket
4. Cushion gasket
5. Frontal cover
6. Fixing plate
7. Bolts
8. Nuts
9. Grinded pipes
10. Metal gasket
11. Vent plug
12. Metal gasket

Transparent housing

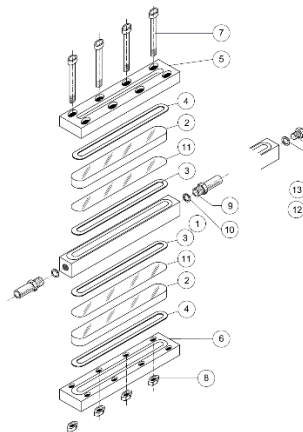

1. Level gauge body
2. Transparent glass
3. Sealing gasket
4. Cushion gasket
5. Frontal cover
6. Back cover
7. Bolts
8. Nuts
9. Grinded pipes
10. Metal gasket
11. Mica shields (optional)
12. Vent plug
13. Metal gasket

8.2

GENERAL USE CAUTION / GLASSES REPLACEMENT



IMPORTANT NOTE for use with water and saturated steam

Assuming that the suitability of the product and its compatibility with the fluid must be checked prior to purchase, if an abnormal erosion of the glass is noted and the need for its frequent replacements, it is possible that the pH value of the water has not been correctly taken into consideration in the process of the level gauge selection. Indeed the length of the crystals depends not only on the operating conditions of the equipment but also on the pH of the water (the higher is the pH and the lower the duration).

In this respect it must be remarked that:

- The DIESSE level gauges are equipped with glasses exclusively of German origin
- The restrictions on the maximum pressure and temperature of use are imposed by the glasses manufacturer. The graph clearly shows the action of erosion caused by steam on an unprotected glass.

Therefore, in the presence of saturated steam, it is always advisable to carefully evaluate the maximum operating conditions of the equipment and consequently choose the most suitable type of level gauge to avoid both maintenance and replacement parts with abnormal frequency and frequent tightenings.

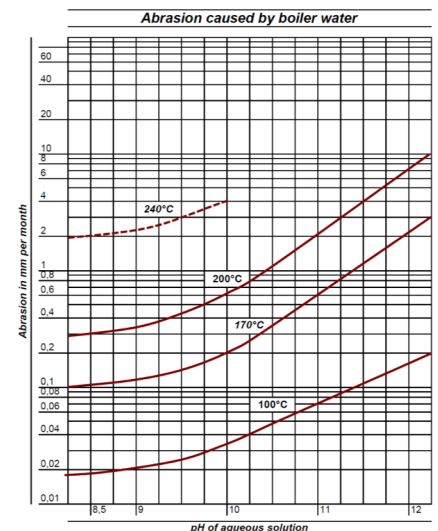

Recommended warnings to be taken into account when ordering:

to avoid frequent tightenings of the union nuts for grinded pipes:

- it is recommended to choose level gauges with grinded pipes when operating conditions don't exceed a maximum pressure of 15 bar (197°C) despite they are suitable for applications up to 20 bar (211°C). This because the contact with steam of the graphite gasket that seals the upper cock, could dry the gasket and generate leakages that might damage externally the whole body and the lower cock.

To avoid frequent replacement of glasses it is recommended:

- To utilize the type at fixed distance between centers in case of operating conditions that don't exceed a maximum pressure of 20 bar (211°C). This because the abrasion caused by steam > 20 bar could cause the glass breakage in a very short time (see the graphic)
- To utilize the transparent level gauge type DS LG-TCF or DS LG-TMF with glasses protected by mica shields up to a maximum pressure of 32 bar (236°C)
- To utilize the transparent level gauge type DS LG-TPF with glasses protected by mica shields up to a maximum pressure of 50 bar (263°C)
- To utilize transparent level gauge type DS LG-TXF with glasses protected by mica shields up to a maximum pressure of 70 bar (280°C)

8.3

GLASSES: CHARACTERISTICS AND LIMITS OF USAGE (Reflex and transparent glasses)

The DIESSE level gauges can be equipped by reflex glasses or transparent glasses. The glasses are manufactured according to the highest quality levels. They are in borosilicate glass, therefore particularly resistant to chemical agents and thermal shock.

Compliance with:

- DIN 7081
- BS 3463
- JIS B 8211
- MIL - G - 16356 D

Physical characteristics:

Coefficient of thermal expansion α 20°C; 300°C: $4,1 \times 10^{-6}/K$
 Density ρ a 25°C: $2,3 \text{ g/cm}^3$
 Young's modulus E: $67 \times 10^3 \text{ N/mm}^2$
 Poisson's ratio μ : 0,20
 Refractive index n_d ($\lambda = 587,6 \text{ nm}$): 1,482
 Abbe number v_d : 64,5
 Internal transmittance at 550 nm: 98,9% a 10 mm thickness

Temperature:

Thermal shock resistance ΔT : 265°C
 Transformation temperature T_g : 545°C
 Maximum permissible temperature: 300°C
 Saturated steam: see recommendations at page 1.59

Chemical characteristic	Hydrolytic resistance	Acid resistance	Alkali resistance
Test according to	DIN ISO 720 Class 1 (HGA1)	DIN ISO 1776	DIN ISO 695 (Identico a DIN 52322) Classe A2
Max abrasion acc. to a DIN ISO	0,1	< 100 $\mu\text{g Na}_2\text{O/dm}^2$	> 75-175 mg/dm^2
Max abrasion	0,050	< 60 $\mu\text{g Na}_2\text{O/dm}^2$	> 100 mg/dm^2

9.

**GLASS LEVEL GAUGES FOR CLASSIFIED AREAS (ATEX)**

Technical data / options: see data sheet available on DIESSE website

DECLARATION OF CONFORMITY – Directive 2014/34/EU

We declare that our instruments (glass level gauge identified by code DS-LG) are in conformity with the requirements of the Directive 2014/34/EU regarding devices intended to be used in potentially explosive atmospheres and they fall in Group II 2° category. Certificate of technical file deposit issued by Notified Body of March 26th, 2018.

The illuminator supplied as accessory of the level gauge is ATEX certified by the manufacturer. See separate instructions and certificate.

Since the level gauges may also be used in environments with potential explosive atmospheres, to ensure a high level of protection, the Customer / User must follow precise instructions and take appropriate precautions as described below.

The installation and use of the level gauge must guarantee the protection of the instrument as well as the people and structures, therefore it is the responsibility of the Purchaser / User proceed as below reported

**RISKS AND RELATIVE CAUTIONS TO BE CAREFULLY FOLLOWED BY THE USER****a. Risk from shocks or thermal shock to the crystals:**

The installation of the gauge must guarantee the safety of the glass parts, therefore the Purchaser/User must ensure that the temperature of the process fluid is the environmental one.

b. Risk of sparks resulting from accumulation of electrostatic charges on the metallic and plastic parts during use, maintenance and cleaning conditions

The gauge is not provided with an earthing connection. The Purchaser/User must evaluate the need for an earthing connection for the entire installation where the indicator is installed.

Moreover, deposits of inflammable dust might form on the indicator. It is advised that maximum effort be made to limit the accumulation of dust by periodically cleaning the surfaces of the indicator.

Accumulation of dust should never exceed a thickness of 5 mm; therefore, it is the responsibility of the User to establish a schedule of cleaning compatible with both his own needs and use of the equipment.

c. Risk of interference amongst the movable parts

During instrument design every precaution has been taken to avoid eventual interference amongst the movable (or manoeuvrable) parts. Therefore, particular attention must be paid by the Purchaser/User in order to avoid this interference during installation.

d. Spark resulting from use of the tool

The use of tools to be utilized during external working operations on level gauge such as grinding, welding, cutting, disconnection from the line, etc., is subject to authorization by the Company Safety Responsible where the equipment is located; in any event, such permission cannot be given in the case of the presence of a potentially explosive atmosphere and in the presence of deposits of dust. These deposits must be eliminated before effecting any work.

Limits of use / of working conditions: see point 1

Limits of Responsibility : see point 1

Accessories: see point 2

The instruments can be equipped with the following accessories:

- Lower and upper safety balls

The Manufacturer reserves the right to make changes to these instructions without prior notice and is not responsible for any printing or transcription errors

- Plugs (for instruments with drain and vent cocks)

Preliminary warnings/recommendations on instrument receipt: see point 3

Warnings/recommendations on instrument storage: see point 3

Use/scope of the instrument: see point 3.1

Improper use: see point 3.2

Installation and start up: see point 4

Tightening control procedure see point 5

Sealing control procedure: see point 6

Dismantling of the level gauge: see point 7

Maintenance: see point 8

10.



LEVEL GAUGES FOR NAVAL APPLICATION

The following types can be installed also on ships:

- DS LG - RBR GR18 - LFC
- DS LG - RBF GR18 - LFC
- DS LG - LG RBF NPV

Product's data / Options: see data sheets available on our website

The above mentioned types can be supplied with LLOYD'S REGISTER APPROVAL (General Design Appraisal) – DAD number TDS/ENG 35168.

It is strongly recommended to carefully check that:

1. Maximum level:
 - The maximum level of the fluid inside the tank is lower than the top connection of the level gauge to the tank for types DS LG-RBR GR18-LFC and DS LG-RBF GR18-LFC
 - The maximum level of the fluid inside the tank is lower than the vent of the level gauge for type DS LG - RBF NPV.
 - A tank is provided under the level gauge to collect possible fluid leakages
2. For application with type DS LG-RBF NPV the vent tube is connected to the tank
3. A proper lateral protection of the whole level gauge is provided (specially of the glasses) and in particular if the instrument is installed near a walking area or goods handling area.

Limits of use and working conditions: see point 1

Additional limits:

- Flash point of the fluid > 60 ° C
- Installation on passenger ships

Limits of responsibility: see point 1

Accessories: see point 2

Preliminary warnings/recommendations on instrument: see point 3

Warnings/Recommendation on instrument storage: see point 3

Use/Scope of the instrument: see point 3.1

Improper use: see point 3.2

Installation and start up: see point 4

Tightening control procedure see point 5

Sealing control procedure: see point 6

Dismantling of the level gauge: see point 7

Maintenance: see point 8

11.

WELD-ON GLASS LEVEL GAUGE

This type of level gauge is designed to be welded on to the tank and withstand the pressure inside it.

Product's data /options: see data sheets available on DIESSE website.

For the assembly and disassembly of the equipment, two people with good technical knowledge of maintenance are envisioned. During the activities, operators must wear appropriate individual personal protective means, and all necessary precautions must be taken to prevent accidents.

To avoid damages to the glasses and gaskets, the welding operation must be done only when the level gauge is disassembled.

Before starting welding operation, it is recommended to properly protect the glass housing and the holes of the tightening screws.

To avoid any deformation or alteration during the working operations of the level gauge, the installer will have to prevent the weakening of the tank providing for the reinforcement of the wall on which the indicator is welded.

During welding operations (which must only be carried out prior to gauge assembly), special care must be taken to avoid exposing the weld-on base to high temperatures for long periods of time as this may compromise the resistance of the gauge when in operation.

If the visibility is longer than 320 mm it is recommended to weld more indicators on the tank, positioned on different axes to avoid any weakening of the tank structure.

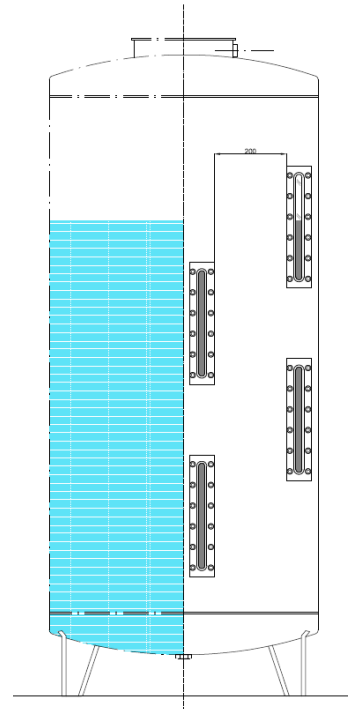

Mounting:**Mounting/assembling of the weld-on level gauge:**

1. Insert the sealing gasket in the weld-on base, put the glass over (if it's a reflex type the prismatic surface must be in contact with the fluid) and then the cushion gasket; in case of a transparent type, if foreseen, insert the mica shields (or the one in PCTFE) between the sealing gaskets and the glass (it must perfectly adhere to the glass surface in contact with the fluid).
2. Position the cover avoiding any movement of glass and gasket, even slightly.
3. Insert all the fitting screws and tighten in the cross sequence below shown
4. See the torque value recommended on the product data sheet

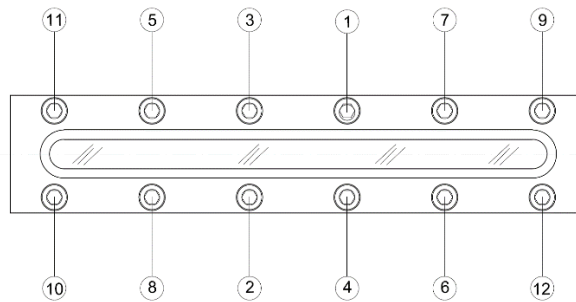

Limits of use, working conditions: see point 1

Limits of responsibility: see point 1

Accessories: see point 2

Preliminary warnings/recommendations on instrument: see point 3

Warnings/Recommendation on instrument storage: see point 3

Use/Scope of the instrument: see point 3.1

Improper use: see point 3.2

Installation and start up: see point 4

Tightening control procedure see point 5

Sealing control procedure: see point 6

Dismantling of the level gauge: see point 7

Maintenance: see point 8

12.

LEVEL GAUGE WITH GLASS TUBE

Level gauges with a glass tube are an inexpensive but valid option for checking the level of non-hazardous or non-reactive fluids in unpressurised tanks.

Product's data /options: see data sheets available on DIESE website.

An external metal protection of the glass tube is always recommended.

The product is NOT suitable for use in the following instances:

- . If it is likely to be exposed to vibrations (glass tube will break)
- . If the installation is situated by a walkway (possibility of blows/impact)
- . If exposed to steam (the steam will shorten glass tube life)
- . In presence of corrosive fluids (example: caustic, fluoridic acid, citric acid.....)
- . If instrument is exposed to thermic shocks

Mounting:

1. Insert the glass tube (1) in the stuffing box gasket that are placed in the shut-off cocks (3) and lightly fasten the press-gasket caps (2)
Note: lubricate outside the glass tube extremities to facilitate the gasket clutch
2. Align the protection (when foreseen) (4) placed on the same axis of the stuffing box calotte (2) and fix the protection with the supplied screw
3. Place the connections of the shut-off cocks on the same axis of the process connections. Fasten the screws with a torque sufficient to guarantee a safe connection but without weakening the material
4. Place the protection (when foreseen), turning it on its vertical axis, in the angular position more suitable to the visibility
5. Tighten the press-gasket caps (2)

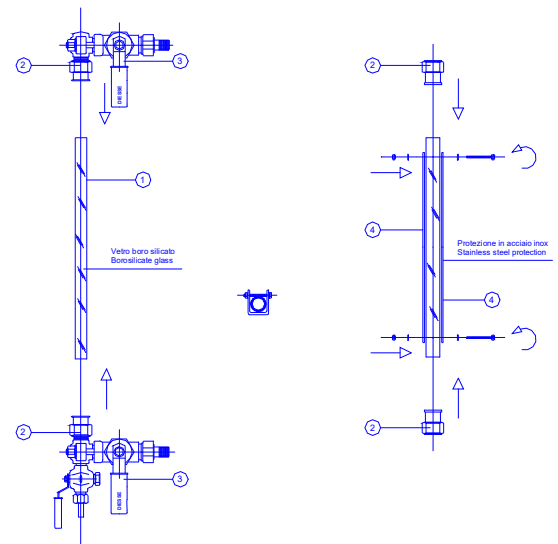

Limits of use, working conditions: see point 1

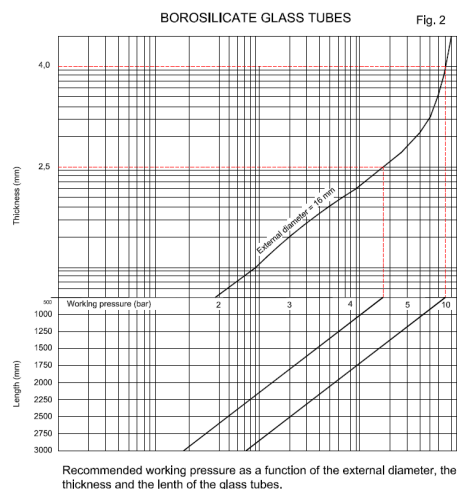

Further recommendations on working conditions:

The Manufacturer still considers data of above graphic purely illustrative as it is always advisable to use the level indicator with glass tube of non-pressurized tanks.

Limits of use, working conditions: see point 1

Limits of responsibility: see point 1

Accessories: see point 2

Preliminary warnings/recommendations on instrument: see point 3

Warnings/Recommendation on instrument storage: see point 3

Use/Scope of the instrument: see point 3.1

Improper use: see point 3.2

Installation and start up: see point 4

Tightening control procedure see point 5

Sealing control procedure: see point 6

Dismantling of the level gauge: see point 7

Maintenance: see point 8

13.



DISPOSAL

To dispose the component parts of the instruments, please observe the current related and in force laws.

14.



TECHNICAL ASSISTANCE

For any need please contact our technical service. To ensure a better service, please indicate the following:

- Type of level gauge
- Date of purchase/of installation of the instrument
- Operating conditions (fluid, pressure and temperature of use)

Our technical department will assess the problem and try to resolve any difficulties where possible. Whenever repairs appear necessary, the manufacturer will agree with the customer the method and time of such repairs. Shipping from customer to the manufacturer is at customer's charge.

For products covered by guarantee

The technical service will effect tests and determine the repairs. Should any responsibility of the manufacturer arise, repairs/replacements will be granted free of charge.

If from analysis of the product it is ascertained that there are no manufacturing defects, and the customer's responsibility for misuse is clear, the manufacturer will charge the customer with all the costs involved.

For products no longer covered by guarantee: the cost of repairs will be debited to the customer based on prior agreement (including the cost of any replacement parts).

15.

GUARANTEE

The guarantee for the level gauge is for 12 months from the date of purchase and can be extended by the manufacturer on the basis of type and characteristics of the product purchased and provided that the customer has complied with storage/handling's recommendations before installation.

It covers eventual manufacturing defects or materials, excluding the parts subject to normal usage such as the gaskets and glasses.

The manufacturer is not responsible for any damage clearly caused by any wrong handling by the forwarder. In case the package is received in damaged conditions it is recommended to accept the material "subject to control/acceptance" so that the conditions of the instrument can be later controlled and, if it's the case, a complaint action can be undertaken towards the courier in charge of transport

The responsibility of the manufacturer is limited to the repair or replacement of the product. The manufacturer is therefore not responsible for eventual damage to other products, structures, personnel directly or indirectly connected to the improper use/installation of the product.

The guarantee is not applicable to consumption material such as glasses and gaskets, disassembled products, repaired or mishandled without the authorisation of the manufacturer. For any problem, therefore, please contact the manufacturer directly in order to evaluate and determine any eventual production defect.

In particular, the guarantee is not valid in the following cases:

- Omitted controls by the user prior to installation, in detail:
 - a) *Verification that the data shown on the product label correspond to the requested product*
 - b) *Verification that the material is both compatible with the fluid of the process and with the ambient/atmosphere in which it is installed*
 - c) *Careful verification that during transport the product has not been damaged*
- Repairs by personnel not authorised by the manufacturer
- Damages caused by fire, short circuits and natural disasters
- Inappropriate handling/installation executed differently from what indicated in the manual of installation-use- maintenance available on company website at the address www.diessefluidcontrol.com
- Fluid non-compatible with the materials used in the construction of the product
- Operating temperature and pressure different from those indicated on the offer /order
- Use of non-original spare parts
- Accidental shocks
- Cleaning of the installation either not effected or not effected correctly (presence of foreign bodies/scales on the installation)
- Water equipment purification not effected (with the consequence of glass erosion)
- Non-suitable package in case of shipment from the Customer to the final User or in case of return from the Customer to the Manufacturer due to a complaint