

## GLASS LEVEL GAUGE TRANSPARENT TYPE PN64 and PN100 / Class 600 DS LG - TPF SHV

Code: DS LG-TPF..... /100/RF-GR18/.../...-M...-CS/CS

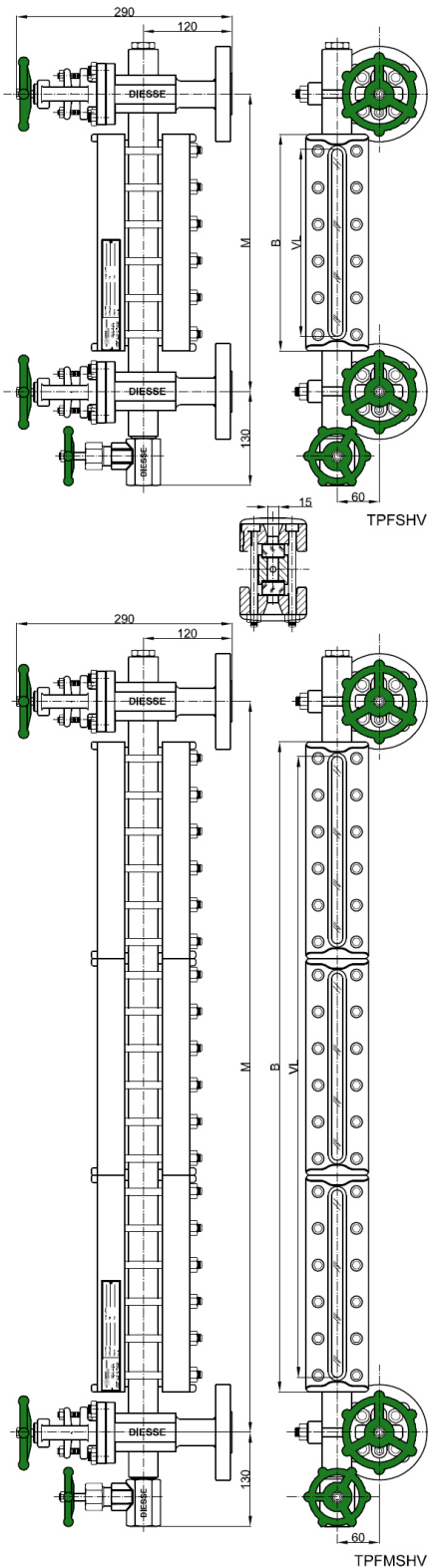

### Technical data

#### Service conditions

Max Pressure: PN64 e PN100; Class 600 (A105: 102 bar @ 38°C; AISI 316L: 99,3 bar @ 38°C)  
Max Temperature: 300°C (According to DIN 7081 for glasses, see page 1.69)

#### View

Standard: front, on request lateral (right or left) adjustable in the production phase  
Note: depending on operating conditions, each element may have one or more internal reinforcements

#### Distance (Centre-to-centre)

Standard: see below table for minimum distance (Fixed distance, not adjustable)  
Option: On request intermediate distances and over 2.000 mm

#### Materials (Standard)

Execution:	CS/CS	SS/CS	SS/SS
Gauge body:	ASTM A105 / A105 LF2	AISI 316L	AISI 316L
Valves body:	A105 LF2	AISI 316L	AISI 316L
Stem, disc / seat valves:	AISI 410 / AISI 316	AISI 316	AISI 316
Non-wetted parts:	Carbon steel galvanized	Carbon steel galvanized	AISI 316

#### Gaskets

Standard: graphite/copper      Option: graphite/AISI 316 or PTFE/AISI316

#### Shut-off valves

DS SHV: globe type  
Handling: by handwheel

#### Process connections:

Standard flanges:      UNI PN64-100 DN15-20-25      ANSI #600/RF DN ¾" - 1"  
Standard threaded unions:      BSP-M ¾" - 1"      NPT-M ¾" - 1"  
Options: further connections types or direct connections to the process without shut-off valves  
(See page 1.53)

**Vent:** Standard: threaded ½" with plug      Option: see page 1.54  
**Drain:** Standard: valve DS DHV threaded ¾"      Option: see page 1.54

#### Glasses

Transparent - Borosilicate glass, "extra hard" and thermally pre-stressed - According to DIN 7081  
Standard: fitted with type B (See page 1.69)

#### Accessories

See from page 1.55

#### Weights

Housing DS TPF: see below table  
Valves DS SHV: Kg. 13,5 approx. (With flanges UNI DN20 PN100)

#### Tightening torque of housing screws

Standard: 75 Nm

#### Spare parts

Housing DS TPF: see from page 1.69 (Drawing with components and parts list see page 1.65)  
Valves DS SHV: see from page 1.74 (Drawing with components and parts list see page 1.68)

CODE	TYPE	BODY Length [mm]	DISTANCE MINIMUM SL [mm]	VISIBLE Length [mm]	GLASS Length [mm]	WEIGHT Housing [Kg]
	x No. el.	B	M = B+80	VL	x No. elements	
11	1x1	130	210	95	115x1	7,9
12	2x1	155	235	120	140x1	9,0
13	3x1	180	260	145	165x1	10,5
14	4x1	205	285	170	190x1	11,5
15	5x1	235	315	200	220x1	12,8
16	6x1	265	345	230	250x1	13,5
17	7x1	295	375	260	280x1	15,4
18	8x1	335	415	300	320x1	16,8
19	9x1	360	440	320	340x1	18,1
24	4x2	410	490	375	190x2	21,5
25	5x2	470	550	435	220x2	24,1
26	6x2	530	610	495	250x2	25,5
27	7x2	590	670	555	280x2	29,3
28	8x2	670	750	635	320x2	32,1
29	9x2	720	800	680	340x2	34,7
36	6x3	795	875	760	250x3	37,5
37	7x3	885	965	850	280x3	43,2
38	8x3	1005	1085	970	320x3	47,4
39	9x3	1080	1160	1040	340x3	51,3
47	7x4	1180	1260	1145	280x4	57,1
48	8x4	1340	1420	1305	320x4	62,7
49	9x4	1440	1520	1400	340x4	67,9
57	7x5	1475	1555	1440	280x5	71,0
58	8x5	1675	1755	1640	320x5	78,0
59	9x5	1800	1880	1760	340x5	84,5

Tab. TPF