

## GLASS LEVEL GAUGE TRANSPARENT TYPE PN40 and PN64 / Class 300 DS LG - TMF GR18

Code: DS LG-TMF... /40/RF-GR18/...-M...-CS/CS

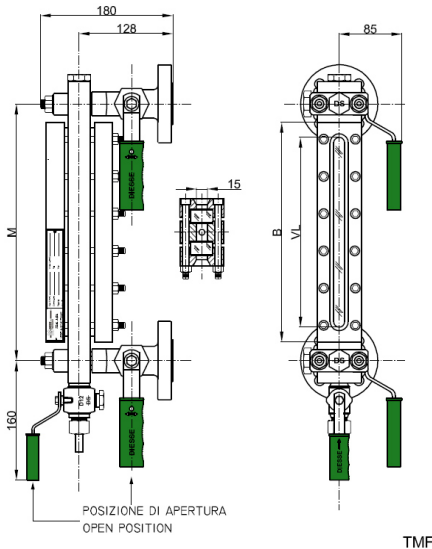

TMF

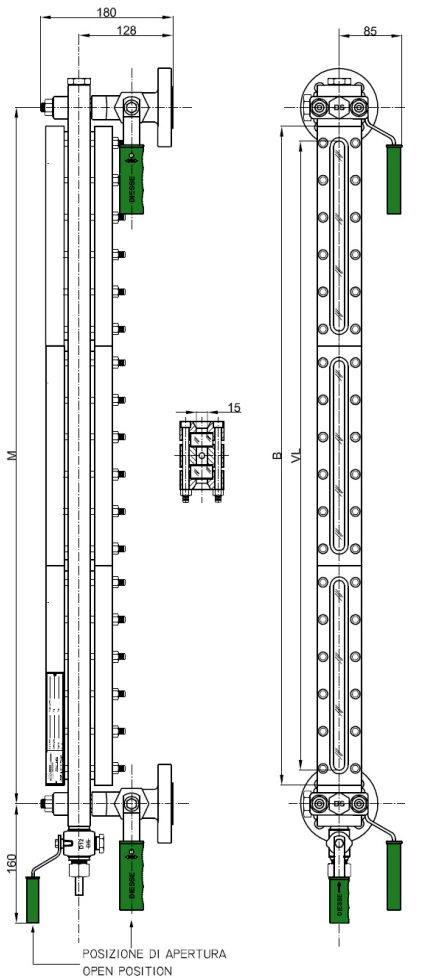

TMFM

### Technical data

#### Service conditions

Max Pressure: PN40 e PN64; Class 300 (A105: 51 bar @ 38°C; AISI 316L: 49,6 bar @ 38°C)  
Max Temperature: 300°C (According to DIN 7081 for glasses, see page 1.69)

#### View

Standard: front, on request lateral (right or left) adjustable in the production phase

#### Distance (Centre-to-centre)

Standard: see below table for minimum distance (Fixed distance, not adjustable)  
Option: On request intermediate distances and over 3.000 mm

#### Materials (Standard)

Execution:	CS/CS	SS/CS	SS/SS
Gauge body & cocks body:	ASTM A105	AISI 316L	AISI 316L
Cocks trim:	AISI 303	AISI 316	AISI 316
Non-wetted parts:	Carbon steel galvanized	Carbon steel galvanized	AISI 316

#### Gaskets

Standard: graphite/copper      Option: graphite/AISI 316 or PTFE/AISI316

#### Shut-off cocks

DS GR18: cylindrical plug type - Straight type - Quick 90° closing  
Handling: lever operated with PP handle (Standard: right; Option: left)

#### Process connections:

Standard flanges:      UNI PN40-64 DN15-20-25      ANSI #150-300/RF DN ½" - ¾" - 1"  
Standard threaded unions:      BSP-M ½" - ¾"      NPT-M ½" - ¾"  
Options: further connections types or direct connections to the process without shut-off cocks  
(See page 1.51)

**Vent:** Standard: threaded ½" with plug

Option: see page 1.52

**Drain:** Standard: cock DS D12 threaded ½"

Option: see page 1.52

#### Glasses

Transparent - Borosilicate glass, "extra hard" and thermally pre-stressed - According to DIN 7081  
Standard: fitted with type B (See page 1.69)      Option: type A (See page 1.69)

#### Accessories

See from page 1.55

#### Weights

Housing DS TMF: see below table  
Cocks DS GR18: Kg. 7,4 approx. (With flanges UNI DN20 PN40)

#### Tightening torque of housing screws

Standard: 35 Nm

#### Spare parts

Housing DS TMF: see from page 1.69 (Drawing with components and parts list see page 1.64)  
Cocks DS GR18: see from page 1.72 (Drawing with components and parts list see page 1.66)

CODE	TYPE	BODY Length [mm]	DISTANCE MINIMUM SL [mm]	VISIBLE Length [mm]	GLASS Length [mm]	WEIGHT Housing [Kg]
	x No. el.	B	M = B+40	VL	x No. elements	
11	1x1	130	170	95	115x1	5,4
12	2x1	155	195	120	140x1	6,1
13	3x1	180	220	145	165x1	6,7
14	4x1	205	245	170	190x1	7,2
15	5x1	235	275	200	220x1	8,1
16	6x1	265	305	230	250x1	8,8
17	7x1	295	335	260	280x1	9,5
18	8x1	335	375	300	320x1	10,4
19	9x1	360	400	320	340x1	11,2
24	4x2	410	450	375	190x2	12,4
25	5x2	470	510	435	220x2	14,2
26	6x2	530	570	495	250x2	15,4
27	7x2	590	630	555	280x2	17,0
28	8x2	670	710	635	320x2	18,8
29	9x2	720	760	680	340x2	20,4
36	6x3	795	835	760	250x3	22,1
37	7x3	885	925	850	280x3	24,5
38	8x3	1005	1045	970	320x3	27,2
39	9x3	1080	1120	1040	340x3	29,6
47	7x4	1180	1220	1145	280x4	32,0
48	8x4	1340	1380	1305	320x4	35,6
49	9x4	1440	1480	1400	340x4	38,8
57	7x5	1475	1515	1440	280x5	39,5
58	8x5	1675	1715	1640	320x5	44,0
59	9x5	1800	1840	1760	340x5	48,0
68	8x6	2010	2050	1975	320x6	52,4
69	9x6	2160	2200	2120	340x6	57,2
78	8x7	2345	2385	2310	320x7	60,8
79	9x7	2520	2560	2480	340x7	66,4
88	8x8	2680	2720	2645	320x8	69,2
89	9x8	2880	2920	2840	340x8	75,6

Tab. TMF