

GLASS LEVEL GAUGE TRANSPARENT TYPE PN25 and PN40

DS LG - TCR SHV

Code: DS LG-TCR...-... /40/RF-SHV/...-...-M...-CS/CS

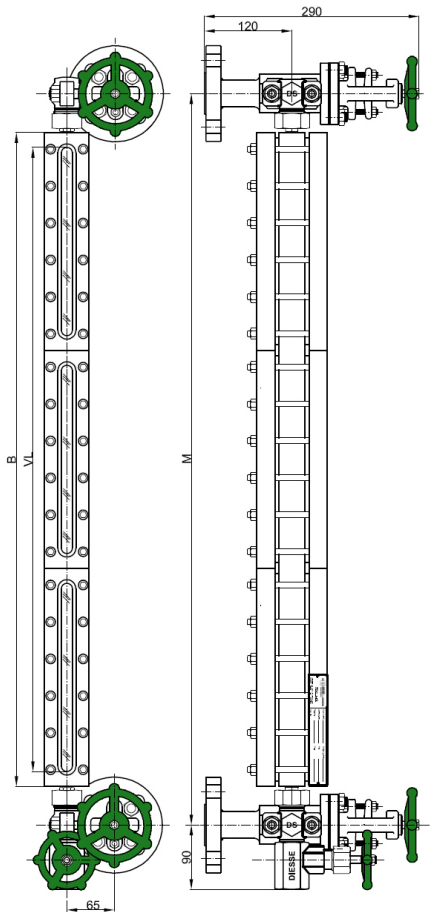
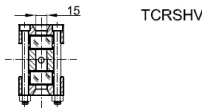
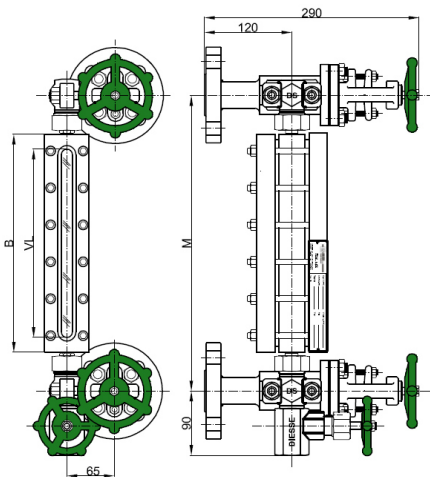

TCRMSHV

Technical data

Service conditions

Max Pressure: PN25 e PN40

Max Temperature: 300°C (According to DIN 7081 for glasses, see page 1.69)

View

Standard: adjustable on 360° in the installation phase

Note: depending on operating conditions, each element may have one or more internal reinforcements

Distance (Centre-to-centre)

Standard: see below table (**Distance adjustable - 0 mm + 10 mm**)

Option: On request intermediate distances and over 3.000 mm

Materials (Standard)

Execution:	CS/CS	SS/CS	SS/SS
Gauge body:	ASTM A105 / A105 LF2	AISI 316L	AISI 316L
Valves body:	A105 LF2	AISI 316L	AISI 316L
Stem, disc / seat valves:	AISI 410 / AISI 316	AISI 316	AISI 316
Non-wetted parts:	Carbon steel galvanized	Carbon steel galvanized	AISI 316

Gaskets

Standard: graphite/copper

Option: graphite/AISI 316 or PTFE/AISI316

Shut-off valves

DS SHV: globe type

Handling: by handwheel

Process connections:

Standard flanges: UNI PN40 DN15-20-25

ANSI #150-300/RF DN ½" - ¾" - 1"

Standard threaded unions: BSP-M ½" - ¾"

NPT-M ½" - ¾"

Options: further connections types or direct connections to the process without shut-off valves

(See page 1.53)

Vent:

Standard: blind

Option: see page 1.54

Drain:

Standard: valve DS DHV threaded ¾"

Option: see page 1.54

Glasses

Transparent - Borosilicate glass, "extra hard" and thermally pre-stressed - According to DIN 7081

Standard: fitted with type A (See page 1.69)

Accessories

See from page 1.55

Weights

Housing DS TCR: see below table

Valves DS SHV: Kg. 11,8 approx. (With flanges UNI DN20 PN40)

Tightening torque of housing screws

Standard: 35 Nm

Spare parts

Housing DS TCR: see from page 1.69 (Drawing with components and parts list see page 1.64)

Valves DS GR18: see from page 1.74 (Drawing with components and parts list see page 1.68)

CODE	TYPE	BODY Length [mm]	DISTANCE SL Pipes L = 57 M [-0/+10 mm]	DISTANCE HL Pipes L = 70 M [-0/+10 mm]	VISIBLE Length [mm]	GLASS Length [mm]	WEIGHT Housing [Kg]
	x No. el.	B	M = B+105	M = B+130	VL	x No. elements	
11	1x1	130	235	260	95	115x1	3,2
12	2x1	155	260	285	120	140x1	3,8
13	3x1	180	285	310	145	165x1	4,3
14	4x1	205	310	335	170	190x1	4,7
15	5x1	235	340	365	200	220x1	5,5
16	6x1	265	370	395	230	250x1	6,0
17	7x1	295	400	425	260	280x1	6,7
18	8x1	335	440	465	300	320x1	7,4
19	9x1	360	465	490	320	340x1	8,1
24	4x2	410	515	540	375	190x2	9,2
25	5x2	470	575	600	435	220x2	10,8
26	6x2	530	635	660	495	250x2	11,8
27	7x2	590	695	720	555	280x2	13,3
28	8x2	670	775	800	635	320x2	14,6
29	9x2	720	825	850	680	340x2	16,0
36	6x3	795	900	925	760	250x3	17,7
37	7x3	885	990	1015	850	280x3	19,8
38	8x3	1005	1110	1145	970	320x3	21,9
39	9x3	1080	1185	1210	1040	340x3	24,0
47	7x4	1180	1285	1310	1145	280x4	26,3
48	8x4	1340	1445	1470	1305	320x4	29,1
49	9x4	1440	1545	1570	1400	340x4	31,9
57	7x5	1475	1580	1605	1440	280x5	32,8
58	8x5	1675	1780	1805	1640	320x5	36,3
59	9x5	1800	1905	1930	1760	340x5	39,8
68	8x6	2010	2115	2140	1975	320x6	43,6
69	9x6	2160	2265	2290	2120	340x6	47,8
78	8x7	2345	2450	2475	2310	320x7	50,8
79	9x7	2520	2625	2650	2480	340x7	55,7
88	8x8	2680	2785	2810	2645	320x8	57,9
89	9x8	2880	2985	3010	2840	340x8	63,5

Tab. TCR